



THE CORPORATION OF THE CITY OF COURTENAY

Community Event Sign Application Sign Bylaw No. 2760, 2013

Please return to Public Works Services located at 1000 Piercy Avenue, or by email to publicworks@courtenay.ca

APPLICANT INFORMATION

Name of Event: _____

Contact Name: _____

Contact Number: _____

Email: _____

SIGN DETAILS

Event Date(s): _____

Installation Date: _____ Removal Date: _____

Proposed Location (please attach a map): _____

Sign Dimensions:

Width (max 1.5m): _____ Sign Height: _____

Sign height including legs (max 2m): _____

What text will appear on the sign: _____

*If your sign includes an image, please provide a copy of the image with this application.

Applicant's Signature

Date (YYYY/MM/DD)

Approved By

Date (YYYY/MM/DD)



THE CORPORATION OF THE CITY OF COURTENAY

INSTALLATION GUIDELINES FOR COMMUNITY EVENT SIGNS

LOCATED ON PUBLIC PROPERTY

General Signs must be freestanding with no more than one sign face and fabricated using weatherproof material, supported by two legs inserted into the grass.

Size of Sign

- The overall sign dimensions must be no greater than 3 square metres (32.3 sq.ft.) in area and no greater than 1.5 metres (4.92 ft) in width.
- When installed, the top of the temporary sign must be no greater than 2 metres (6.56 ft) above grade.

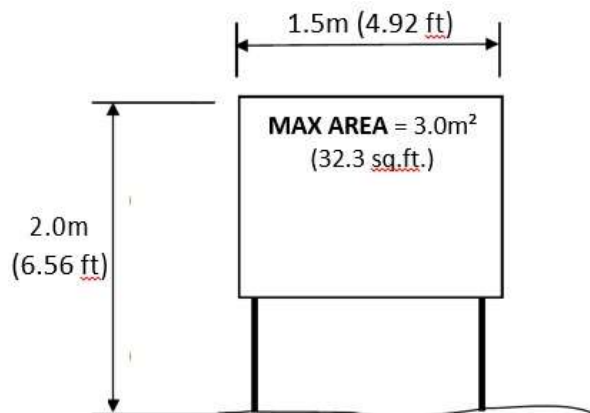

Location of Sign

- Must be a minimum of 30 metres from the nearest intersection.
- Must be a minimum of 2 metres from the edge of any travelled lane and may not conflict with pedestrians, bicycles or vehicles.
- Signs may not encroach onto sidewalks, multi-use paths or bike lanes. Signs within proximity to pedestrians and/or cyclists must have a minimum clearance of 2 metres from the ground surface to the bottom of the sign.
- No sign shall interfere with or obstruct any traffic control device.
- Signs must be placed on public property only.

Mounting and Installation of Sign

- Signage must be fabricated using coroplast, plastic or similar lightweight material.
- Signage legs may be inserted no more than 30 centimetres into the grass.
- The applicant will be responsible for any liability occurring as a result of any sign installation.
- All signs and their supporting structures shall be maintained in good condition at all times.
- Any sign that poses a safety risk or hazard to persons or property, as determined by the City, shall be repaired or removed by its owner within 24 hours of receiving notice from the City. If the sign is not repaired or removed within 24 hours the City may remove the sign on the applicant's behalf. Any costs incurred by doing so may be invoiced to the applicant.

Duration of Sign Installation

- Signs may be installed for a maximum of 30 days.
- Signs must be removed no later than 7 days after the event is held.

I, _____, hereby acknowledge that I have read, understand, and agree to the requirements as outlined above.

Applicant Name – Please Print